

ZENITH

FUEL SYSTEMS LLC

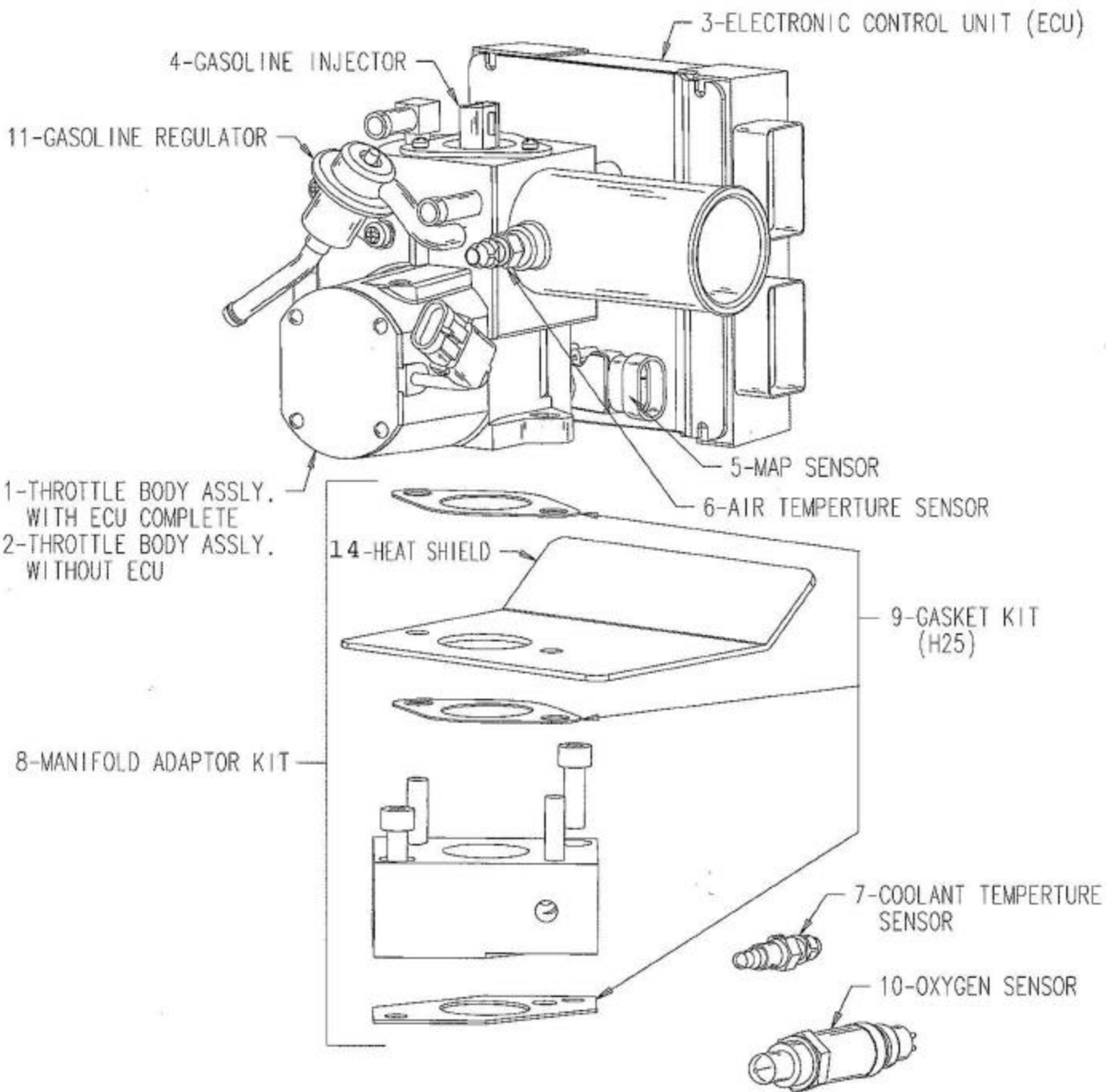

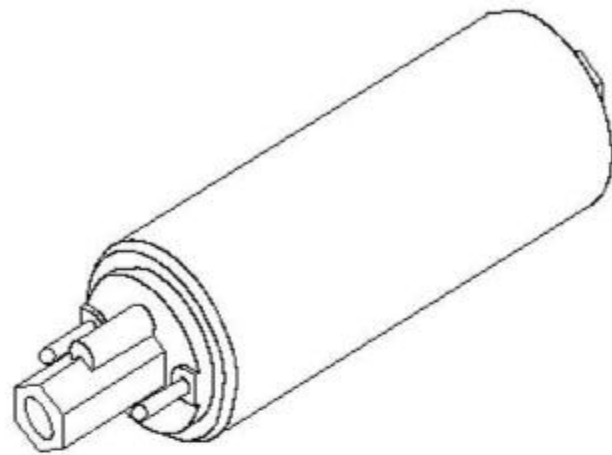

12 - GASOLINE
PUMP

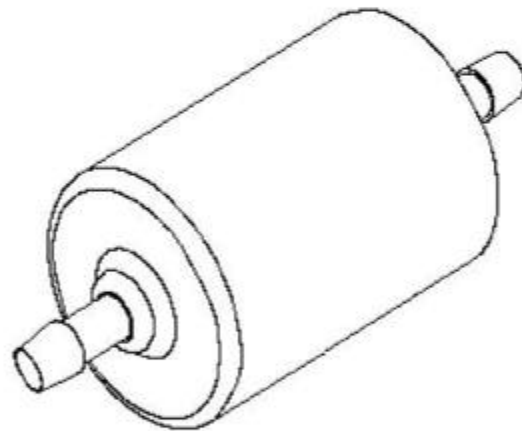

13 - GASOLINE
FILTER

(20110) MINUTEMAN POWERBOSS SERVICE PARTS LIST

ZENITH H25 EPA/CARB COMPLIANT FUEL SYSTEM

ITEM #	PART DESCRIPTION	SERVICE PART NUMBER
1	THROTTLE BODY W/ECU	C282-20110
2	THROTTLE BODY W/O ECU	C282-20110W
3	ENGINE CONTROL UNIT (ECU)	C282-326-60
4	GASOLINE INJECTOR (O-RINGS INCL.)	C282-349
4A	O-RING KIT (GASOLINE INJECTOR & FUEL PRESSURE REG.)	C282-14
5	MANIFOLD ABSOLUTE PRESSURE SENSOR (MAP)	C282-239
6	AIR TEMPERATURE SENSOR	C282-6
7	ENGINE COOLANT TEMPERATURE SENSOR (ECT)	C282-298
8	MANIFOLD ADAPTOR KIT W/HARDWARE & GASKETS	C282-114
9	MANIFOLD GASKET KIT	C282-327
10	HEATED EXHAUST OXYGEN SENSOR	C282-355
11	GASOLINE FUEL PRESSURE REGULATOR (O-RING INCL.)	C282-281
12	GASOLINE FUEL PUMP (INLINE)	C282-238
13	GASOLINE FUEL FILTER (3/8 BARB)	C282-224
14	HEAT SHIELD	C282-235
15	ENGINE WIRING HARNESS	E784-146

	CONDITION	RESULT	TROUBLE CODE	TROUBLE FLAG	CODE/FLAG RETAINED IN MEMORY WITH KEY OFF?	CHECK ENGINE LIGHT	OPTIONAL FAULT LIGHT
1	ENGINE OIL PRESSURE SWITCH INDICATES LOW OIL PRESSURE	OIL PRESSURE SWITCH INDICATES OIL PRESSURE IS LOW FOR 1 COMPLETE SECOND - ENGINE SHUTDOWN OCCURS (AFTER 5 SECOND BYPASS DELAY UPON STARTUP)		2	NO	FLASHES CONTINUOUSLY - ALERTS OPERATOR ENGINE SHUTDOWN HAS OCCURRED	
2	ENGINE OVERHEATING DETECTED	COOLANT TEMPERATURE INDICATES OVER HEATING CONDITION (AFTER 40 SECOND HOT SOAK TIME DELAY UPON STARTUP)		3	NO	FLASHES CONTINUOUSLY - ALERTS OPERATOR ENGINE SHUTDOWN HAS OCCURRED	
3	AUXILIARY DEVICE INDICATES FAULT (CUSTOMER DEFINED)	FLASHES CONTINUOUSLY - ALERTS OPERATOR ENGINE SHUTDOWN HAS OCCURRED		4	NO		FLASHES CONTINUOUSLY - ALERTS OPERATOR ENGINE SHUTDOWN HAS OCCURRED
4	AUXILIARY DEVICE INDICATES FAULT (CUSTOMER DEFINED)	FLASHES CONTINUOUSLY - ALERTS OPERATOR ENGINE SHUTDOWN HAS OCCURRED		5	NO		FLASHES CONTINUOUSLY - ALERTS OPERATOR ENGINE SHUTDOWN HAS OCCURRED
5	BEGINNING OF DIAGNOSTIC ROUTINE	NO FAULT CONDITION EXISTS - SIGNIFIES BEGINNING OF FLASH CODES	12		YES-ALWAYS PRESENT	ALWAYS FLASHES CODE 12 AT THE BEGINNING OF DIAGNOSTIC CYCLE- SIGNIFIES CIRCUIT IS OPERATIONAL	
6	ENGINE COOLANT SENSOR INDICATES OPEN CIRCUIT	TROUBLE CODE IS STORED IN MEMORY	14		CODE RETAINED IN MEMORY	UPON INITIAL FAULT- CHECK ENGINE LIGHT WILL FLASH CONTINUOUSLY ALERTING OPERATOR ENGINE SHUTDOWN HAS OCCURRED - UPON RESTART, "CHECK ENGINE" LAMP IS ON CONTINUOUS INDICATING CODE WAS STORED	
7	ENGINE COOLANT SENSOR INDICATES SHORT CIRCUIT OR EXTREME OVERHEATING OF ENGINE (COOLANT TEMP \geq 266 F)	TROUBLE CODE IS STORED IN MEMORY	15	3	CODE RETAINED IN MEMORY	ON CONTINUOUS WHILE ENGINE IS RUNNING INDICATING CODE WAS STORED	
8	PEDAL POSITION SENSOR OVER VOLTAGE (OVER 4.5 VOLTS)	TROUBLE CODE IS STORED IN MEMORY	21		CODE RETAINED IN MEMORY	ON CONTINUOUS WHILE ENGINE IS RUNNING INDICATING CODE WAS STORED	
9	PEDAL POSITION SENSOR UNDER VOLTAGE (0 VOLTS)	TROUBLE CODE IS STORED IN MEMORY	22		CODE RETAINED IN MEMORY	ON CONTINUOUS WHILE ENGINE IS RUNNING INDICATING CODE WAS STORED	
10	AIR TEMPERATURE SENSOR INDICATES OPEN CIRCUIT	TROUBLE CODE IS STORED IN MEMORY	23		CODE RETAINED IN MEMORY	ON CONTINUOUS WHILE ENGINE IS RUNNING INDICATING CODE WAS STORED	
11	AIR TEMPERATURE SENSOR INDICATES SHORT CIRCUIT	TROUBLE CODE IS STORED IN MEMORY	24		CODE RETAINED IN MEMORY	ON CONTINUOUS WHILE ENGINE IS RUNNING INDICATING CODE WAS STORED	
12	MAP SENSOR CIRCUIT INDICATES HIGH VOLTAGE (4.98 V OR ABOVE)	TROUBLE CODE IS STORED IN MEMORY	33		CODE RETAINED IN MEMORY	ON CONTINUOUS WHILE ENGINE IS RUNNING INDICATING CODE WAS STORED	
13	MAP SENSOR CIRCUIT INDICATES SHORT TO GROUND	TROUBLE CODE IS STORED IN MEMORY	34		CODE RETAINED IN MEMORY	ON CONTINUOUS WHILE ENGINE IS RUNNING INDICATING CODE WAS STORED	
14	OXYGEN SENSOR - LEAN CONDITION DETECTED	TROUBLE CODE IS STORED IN MEMORY	44		CODE RETAINED IN MEMORY	ON CONTINUOUS WHILE ENGINE IS RUNNING INDICATING CODE WAS STORED	
15	OXYGEN SENSOR - RICH CONDITION DETECTED	TROUBLE CODE IS STORED IN MEMORY	45		CODE RETAINED IN MEMORY	ON CONTINUOUS WHILE ENGINE IS RUNNING INDICATING CODE WAS STORED	